

Intelligent Mail® barcode Description

The USPS is transitioning to the new Intelligent Mail® barcode as an improvement to the existing POSTNET™ barcode. The Intelligent Mail® barcode is a 65-bar USPS barcode used to sort and track letters and flats. Unlike the POSTNET barcode that only contains the delivery point ZIP Code, the new Intelligent Mail® barcode contains additional fields like the Service Type Identifier, Sequence number and Mailer ID which expands your ability to track individual pieces and provides greater visibility into the mailstream. With this Intelligent Mail® barcode, you can request services like tracking and address correction all in one barcode. The Intelligent Mail® barcode allows you to number your mail so that you can uniquely identify each mail piece in your mailing. It contains a Mailer ID Field that allows you to obtain data about your mailings.

Decoding the Intelligent Mail® barcode

There are two formats of the Intelligent Mail® barcode. The format you use depends upon the Mailer ID assigned to you by the USPS.

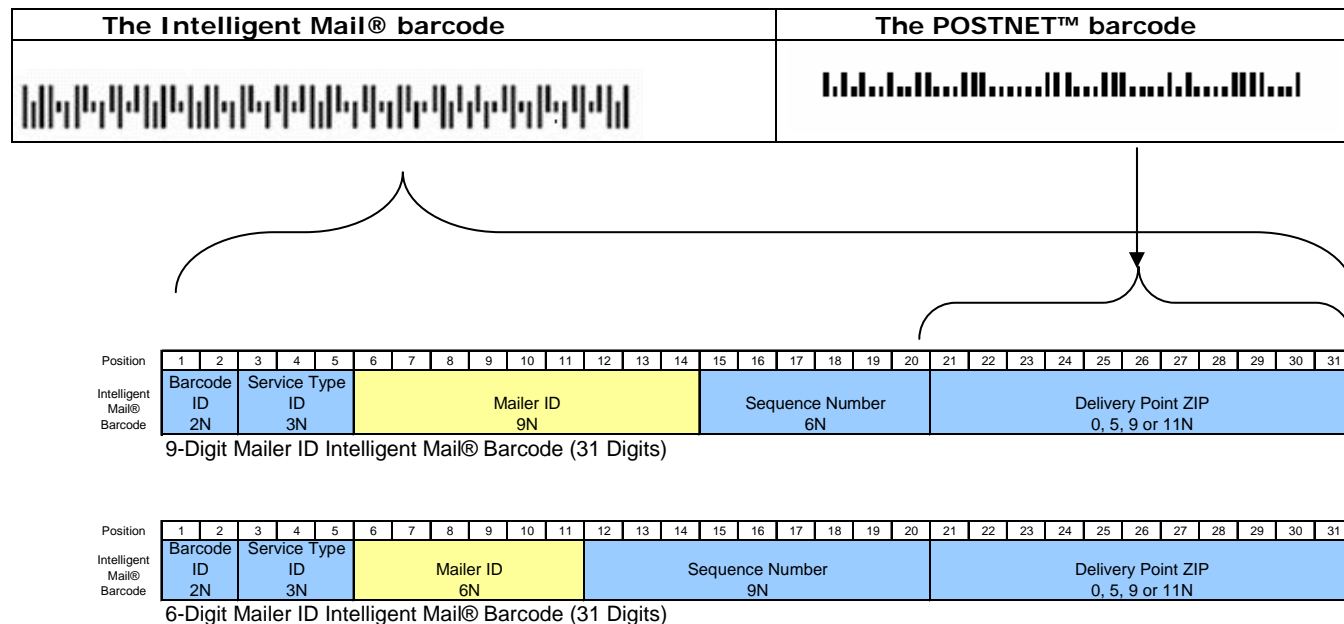

Barcode ID: The barcode identifier is a 2-digit field that is reserved to specify the presort makeup. If you currently do not use an Optional Endorsement Line, you will simply populate this field with "00".

Service Type Identifier: Used to request special services such as tracking or address correction. If you are not requesting special services on the mail piece, you should use one of the following codes depending upon the class of mail to which the Intelligent Mail® barcode is applied:

700 for First-Class mail; 702 for Standard mail; 704 for Periodicals; 706 Bound Printed Matter.

Mailer ID (MID): This is an ID that the USPS will assign to you to use in your Intelligent Mail® barcodes. The USPS will issue you a 9-digit or a 6-digit Mailer ID based on your mail volume. Mailer IDs are obtained by making a request from the subscription process helpdesk supporting your product or service. Subscribers of OneCode Confirm™ should call 800-238-3150 and Confirmation and Extra Services customers should call 877-264-9693. OneCode ACS™ subscribers should call 877-640-0724. Mailer IDs for letters and flats when there are no plans to subscribe to OneCode Confirm or OneCode ACS can be obtained by contacting the local Mailpiece Design Analyst (MDA) via http://pe.usps.gov/mpdesign/mpdfr_mda_intro.asp.

Sequence or Serial Number: You can use this field to uniquely identify your individual mail pieces. If you are assigned a 9-digit MID, you will have 6-digits to identify and number your mailpieces. If you are assigned a 6-digit MID, you will have 9 digits to identify and number your mail pieces.

Delivery Point ZIP Code: Populate this field with delivery point ZIP Code of the mail piece.

For detailed information on how to populate the Intelligent Mail® barcode, please access the Intelligent Mail® barcode specification and Technical Resource Guide from <http://ribbs.usps.gov/onecodesolution/>